



*Premium quality sensor for the measurement of visibility in the most demanding applications*

*Reliable operation in all weather conditions*

*Compact forward scatter design simplifies installation and system integration, whilst providing accurate measurements*

## KEY FEATURES & BENEFITS

- Reliable measurement in all weather conditions
- Highly corrosion resistant hard coat anodised finish
- Window contamination monitoring and compensation
- Unaffected by obstacle warning lights
- Easy integration of Biral ALS-2 Ambient Light Sensor
- Mains or DC powered
- 10m to 99.99Km measurement range
- 5 Years Warranty

**The VPF-710 Visibility sensor provides high quality visibility measurement in a compact and robust package. The open design of the sensor head allows the free passage of air ensuring the visibility measurement is as accurate as possible in all conditions. Other features of the design ensure reliable results in all precipitation types as well as smoke and dust.**

## Visibility Measurement

The measurement of visibility by forward scatter as used by the VPF-710 is now widely accepted and seen as having significant advantages over more traditional techniques such as the use of transmissometers or backscatter sensors. Backscatter sensors share the VPF-710's advantage of being compact however the backscatter signal is strongly dependent on the type of obstruction to vision resulting in poor accuracy and limited upper range. Transmissometers were once considered the gold standard of visibility measurement due to their advantage of direct visibility measurement, however the limited measurement range, high cost of acquisition, large size and significant maintenance costs have resulted in their use being limited to a few specialist applications. The VPF-710 by contrast is compact, requires little maintenance and has a visibility range of 10m to 75km, whilst its measurement performance has been proven to be comparable to that of a transmissometer. The calibration of the VPF sensor family was undertaken in accordance with the recommendations of ICAO 9328 and is traceable to a national weather service transmissometer.

Visibility measurements are reported as forward scatter Extinction Coefficient (EXCO) or Meteorological Optical Range (MOR) in the range of 10m to 99.99km. The features and

accuracy of the VPF-710 ensure it complies with ICAO and WMO specifications for aviation use including Runway Visual Range systems.

## Rugged and Reliable

Our sensors are often installed in challenging environments, such as offshore platforms, where meteorological information is essential for operational safety. The sensor's physical design is optimised to ensure accurate measurement and reliable operation even where driving rain and salt spray is a common occurrence. Low power heaters keep the windows free from dew whilst high power heaters are optionally available to keep the optics free of blowing snow.

The operational life of a typical VPF series sensor is well in excess of ten years, even in a marine environment, due to the hard coat anodise finish applied to the aluminium enclosure. The calculated Mean Time Between Failure (MTBF) is over 6 years, however field return data gives a figure in excess of 35 years.



## Applications

In many applications and especially those connected with offshore and general aviation the costs of servicing or replacing a sensor can be significant. When the equipment is installed offshore access is difficult and expensive, whilst for any aviation use there are significant costs due to restrictions imposed when equipment is not operational. Many VPF series installations are in the most extreme of environments where they have a reputation for reliability and long life.

Aviation applications demand accurate measurement of visibility to help ensure safety. The VPF-710 meets or exceeds all international specifications for visibility measurement with a reliability that is proven through worldwide use. The accuracy and quality of the VPF series is recognised by these being the first forward scatter sensors to be used for Runway Visual Range (RVR) on CAT III runways approved by the UK CAA.

The VPF7-710 is widely used in wind energy applications to control the intensity of aviation obstacle warning lights. Mounted on the turbine nacelle the sensor is exposed to extremes of the weather and is subjected to light from the high intensity obstacle warning lights. The rugged design allows the VPF-710 to easily cope with the weather and vibration from the

turbine whilst the electro-optic design ensures that not even flashing IR lights disturb the visibility measurement. The design features of the VPF-710 make it equally applicable to many other applications including national weather service networks and research applications.



## Interfacing and Connectivity

All VPF series sensors are designed to be easy to use, with the ASCII text data message transmitted at user defined time periods or in response to a polled request. The standard data message provides EXCO or MOR. An optional interface to the ALS-2 Ambient Light Sensor simplifies use in aviation applications where RVR information is required. The ALS-2 Ambient Light Sensor data is appended to the standard sensor data message simplifying both the installation and data processing.

To keep track of the operational status of the sensor, abbreviated self-test information is included in every data message with a full self-test report available on request.

## Cost of Ownership

Even the most reliable sensor can have a high cost of ownership if it requires constant maintenance. The VPF-710 has a series of features that reduce maintenance requirements to a minimum whilst ensuring accurate and reliable operation. These features include window contamination monitoring which automatically corrects the output data and provides two stage warnings allowing maintenance to be performed as efficiently as possible. Calibration checks and recalibration are simple and quickly accomplished in the field by a single person. The need for such procedures is limited however as the stability of the light source and receiver circuitry is such that recalibration intervals are typically measured in years.

The VPF-710 is either mains or DC powered. Hood heaters are available for use in areas prone to snow.

## Advanced Functional Test Mode

All Biral visibility and present weather sensors have the capability to temporarily output specific data via a test mode. In this mode the user can define visibility, window contamination and fault conditions for a pre-determined time period. This functionality is useful during Factory or Site Acceptance Testing (FAT or SAT), or system integration to test downstream processing of the output data.

## Sensor Configuration Information

For a detailed explanation of the configuration options please refer to the table below.

### 71 – VPF-710 Sensor

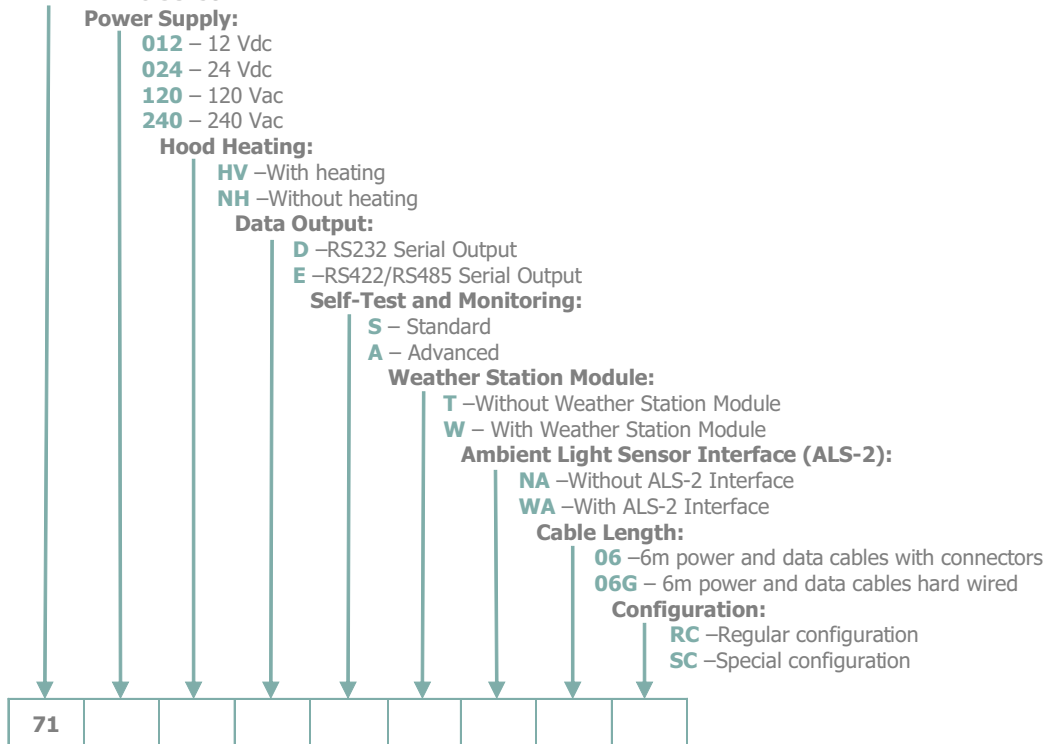

**Example:** 71.024.NH.D.A.T.WA.06.RC (Please use this code when ordering your sensor).

## Configuration Options Explained

Option	Description
Power Options	The sensor is available with a range of power supply options. Option <b>012</b> : 12 Vdc supply Option <b>024</b> : 24 Vdc supply Option <b>120</b> : 120 Vac supply Option <b>240</b> : 240 Vac supply
Heating Options	Heated hoods are available to stop snow from accumulating around the optical windows. The hood heating option is only required in regions where snow is experienced. 12 Vdc sensors are supplied with lower power hood heaters. Option <b>HV</b> : Hood heating included Option <b>NH</b> : No hood heating
Data Output	The sensor is available with either RS232 or RS422/RS485 serial communications. Option <b>D</b> : RS232 Serial communication Option <b>E</b> : RS422/RS485 Serial communication
Self-Test	The sensor may be configured for either Standard or Advanced Self-Test. The standard self-test option provides monitoring of all the essential sensor functions and contamination of the transmitter window. The advanced self-test option adds receiver window contamination monitoring and receiver sensitivity monitoring. Monitoring of receiver contamination is useful in applications where different levels of contamination may occur on the sensor windows, for example where strong gusty winds are experienced. Option <b>S</b> : Standard Self-Test Option <b>A</b> : Advanced Self-Test
Weather Station Module	The sensor can be configured to accept three 0-10V analogue inputs; this is called the Weather Station Module. Option <b>T</b> : Without Weather Station Module Option <b>W</b> : With Weather Station Module
ALS-2 Interface	The sensor may be configured to allow direct connection of the ALS-2 Ambient Light Sensor. The Ambient Light Sensor is typically used in airport applications where Runway Visual Range must be calculated. Option <b>NA</b> : Without Ambient Light Sensor Interface Option <b>WA</b> : With Ambient Light Sensor Interface
Power and Data Cable	The sensor is supplied with either cables for connection to the sensor using circular connectors or with fixed cables through plastic cable glands. The standard length of all cables is 6m; other lengths are available in multiples of 1m. Option <b>06</b> : Standard 6m cable Option <b>06G</b> : 6m fixed cables through cable glands
Configuration	Reserved for customer specific configurations. Option <b>RC</b> : No customer specific configuration. Option <b>SC</b> : Special customer specific configuration.

# VPF-710

## Visibility Sensor

### Specifications



#### Visibility Measurement

Measures	Visibility (EXCO as standard - MOR available as a special configuration)
Output	Serial data
Range (visibility)	10m to 99.99km
Measurement Error	≤1.3% at 600m, ≤1.8% at 1,500m, ≤2.0% at 2km, ≤8.3% at 15km, ≤10.5% at 30km, ≤20% at 75km
Measurement principle	Forward scatter meter with 39° to 51° angle, centred at 45°

#### Outputs and Reports

Output rate (seconds)	10 to 300 (selectable)
Serial outputs	RS232 as standard RS422/RS485 as an option

#### Power Requirements

Sensor Power	12Vdc 24Vdc 120Vac 240Vac
Hood heating power	As sensor supply
Basic sensor	6W
Hood heaters	30W (17W for 12V sensor)

#### Additional Features

Window heaters	Fitted as standard
Window contamination monitoring	Fitted as standard on the transmitter window. Optional on the receiver window
Hood heaters	Optional

#### Environmental

Operating temperature	-50°C to +60°C
Operating humidity	0 – 100% RH
Protection rating	IP66

#### Certification & Compliance

CE Certified
EMC compliance with EN61326-1997, 1998, 2001
RoHS and WEEE compliant

#### Physical

Material	Hard coat anodised aluminium
Weight (sensor head)	4.9kg DC sensors 6.1kg AC sensors
Length	751mm
Warranty	5 years
Lifetime	>10 years
MTBF (MIL-HDBK-217F)	6.5 years (56,700 hours)
MTBF (Service return calculation)	>35 years

#### Maintenance

Self-test capability	As standard
User confidence check	6 months recommended
Window Cleaning	Automatic compensation and warnings
Field calibration	With optional calibration kit

#### Included with Sensor

The sensor is delivered in sturdy recyclable foam filled packaging with:	
- Pole mounting kit (1 x U-bolt)	
- 6m power and data cable	
- User manual and calibration certificates	

#### Accessories – Optional

70.CAL	VPF Series Calibrator
70.CASE	VPF Series Transit Case
70.SK	VPF Series Spares Kit
75.WTY	1 Year extended warranty

Specifications are subject to review and change without notice. E&OE.

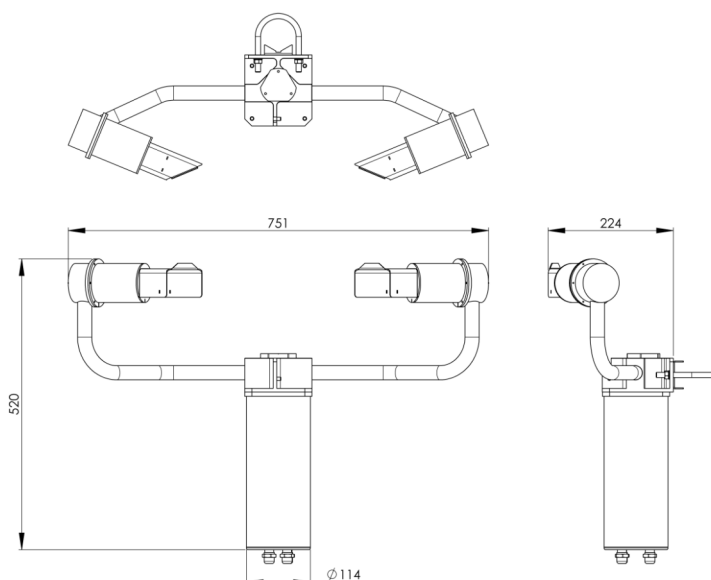

Dimensions in mm

GWU-Umwelttechnik



Bonner Ring 9  
50374 Erftstadt, Germany  
☎ + 49 (0) 2235 95522 0  
✉ info@gwu-umwelttechnik.de  
🌐 www.gwu-umwelttechnik.de